

Lock Table Assembly

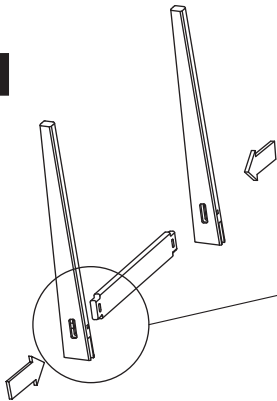

You will need: a standard hammer

1



Slide the appropriate legs onto the cross bars.

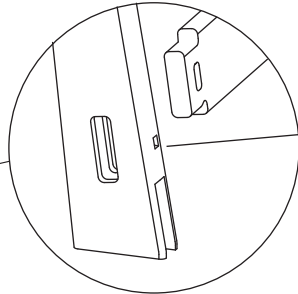

Ensure the square hole is positioned on the inner side of the leg nearest to the crossbar.

Check the legs are tilted in the same direction!

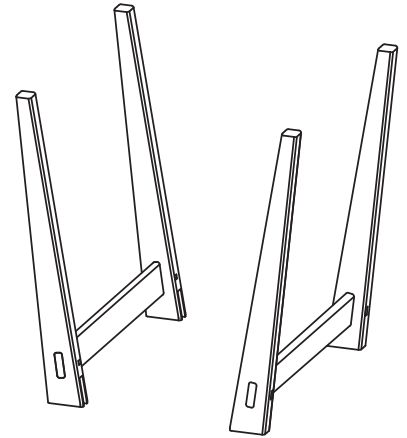

2

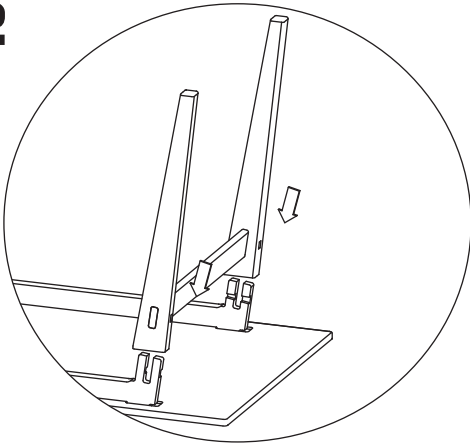

Using only your hands, and NOT a hammer, slide each pair of legs onto the table top braces making sure to keep the cross bar horizontal at all times.

3

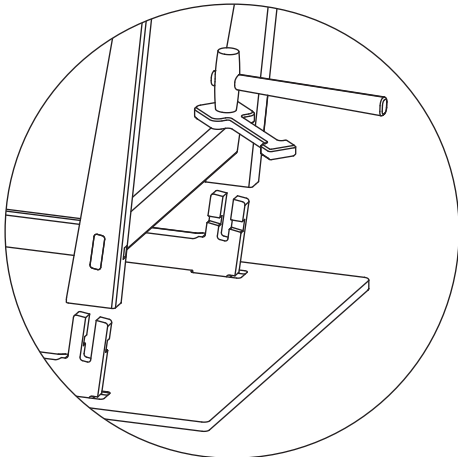

To ensure the stiffness of the table, the last 10mm needs to be hammered in.

Use your hammer, protecting the crossbar with the paddle provided.

The correct position is achieved when the gap between the leg and the table brace is fully closed.

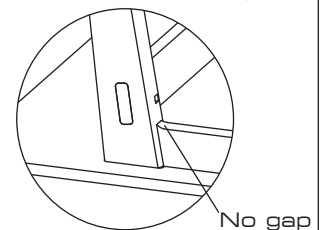
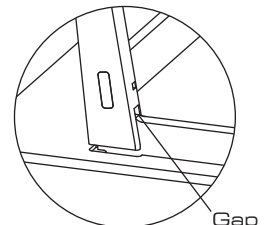

4

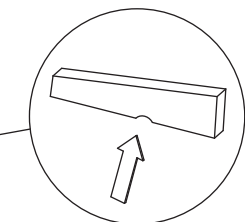
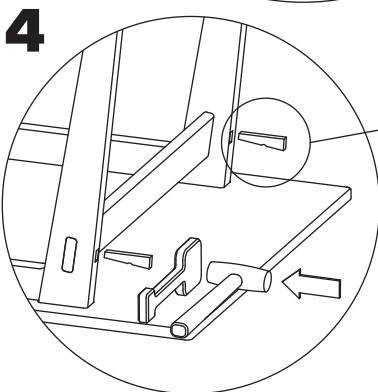

The notch in the pin needs to face the table top.

Push the pins in.

Use a hammer and the paddle provided to ensure the pin finishes flush.

The completed table.

